

## LD1094

### HIGH-POWER ADJUSTABLE INTERIOR/ EXTERIOR RECESSED LED DOWNLIGHT



The LD1094 is an IP67 rated high-power adjustable recessed downlight, designed for challenging marine environments. Featuring an innovative 360° rotating ball-joint, the deep recessed lens assembly can be positioned in any direction and tilted up to 25° for ultimate flexibility. After installation, focusing can be carried out quickly and glare control accessories interchanged by unscrewing the bezel, eliminating the need for the product to be removed from the mounting surface. With a shallow depth of just 67mm, this product is ideal for areas with a height restriction and provides a wide range of hidden fixing options to suit a variety of ceiling types. The LD1094 delivers in excess of 750lm and is available with N1 LED engine offering colour temperatures between 2200K-5000K, as well as several beam angles for multi-purpose use of the fitting throughout a project. This robust downlight solution ensures excellent thermal and light output performance that is built to last in harsh applications.



## KEY FEATURES

- > Innovative 360° rotating ball-joint can be positioned in any direction and tilted up to 25° for ultimate flexibility when focusing onsite
- > Removable bezel for quick and easy on-site focusing once the product is installed
- > Very shallow depth, ideal for height restricted applications
- > Rated IP67 from the front and IP65 from the back
- > Interchangeable optics and glare control accessories including honeycomb louvre
- > Beam angles include 28° medium spot , 35° medium, 46° wide, 65° extra wide and a 22 x 43° oval beam
- > Single optic produces superior beam shape and no multiple shadows
- > High quality machined bezel available in: Polished & Passivated 316 Stainless Steel, 316 Stainless Steel, White (RAL 9016), Black (RAL 9005), Antique Bronze, Satin Antique Brass, Satin Brass, Anthracite Grey (RAL 7016) and any RAL
- > N1 LED engine, producing up to 755 lumens in 3000K
- > Various hidden fixing methods for multiple ceiling types
- > Switched, 0-10V, Casambi, DMX, DALI or Mains dimmable drivers available

## DIMENSIONS

*Dimensions in mm*

For full dimensions please go to page 5.

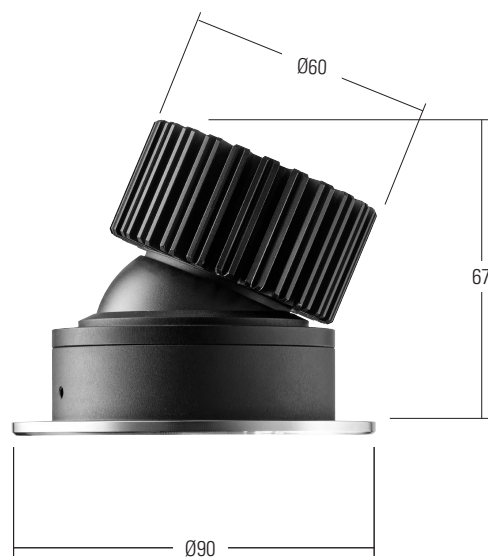

## SPECIFICATION

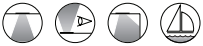
Engine	 N1		
Beam angles	28°, 35°, 46°, 65°, 22 x 43°		
LED manufacturer	CREE		
Colour temperature*	2200K/ 2700K/ 3000K/ 4000K/ 5000K		
Current	350mA	500mA	700mA
LED power (Max)	5.8W (7W**)	8.3W (10W**)	11.6W (14W**)
Delivered lumens (L <sub>100</sub> )	431	586	755
Lumens per circuit watt	74	71	65
CRI (Min)	90+		
Forward voltage (V <sub>100</sub> )	18.5V		
Colour consistency	2 SCDM		
Peak intensity	2690 cd		
LED Lumens (at max output)	1393		
LOR	0.54		
TM30	RF90	RG102	
UGR***	13.9		
LED lifetime	L90B5 at 90,000hrs		
Applications			

These values are based around a LD1094 -N1-700-LW30-MSB

\* See lumen variance table to the right

\*\*indicates the nominal power for the LED run at that particular current and includes losses associated with using an 85% efficient driver

\*\*\*UGR values based on room parameter of 4H 8H, C70 W50 F20

Lumen variance by CCT	
2700K	+/- 0%
4000K	+7%
5000K	+16%

## MECHANICAL

Ambient temperature	-20° to 35° (700mA) or -20° to 40° (500mA) or -20° to 55° (350mA)
Glass	3mm thick, low iron glass
Materials	Black anodised aluminium body, 316 stainless Steel bezel
Weight of product	0.435kg
IP rating	IP67 (from front) IP65 (from back)
Wiring	In-series constant current wiring (Pre-wired with 2 core cable at a length of 350mm)

AVAILABLE FINISHES

*Please refer to our finishes guide for full details*

POLISHED & PASSIVATED 316 STAINLESS STEEL

- > Marine Grade 316 Steel
- > Mirror like finish
- > Extremely durable
- > Passivated to extensively prolong resistance to corrosion and brown stains caused by oxidation in marine environments
- > Interior & exterior use

316 STAINLESS STEEL

- > Marine grade 316 Steel
- > Standard machined finish
- > Extremely durable
- > Passivation recommended for marine environments to prevent corrosion and build up of brown stains caused by oxidation
- > Interior & exterior use



PAINT FINISH

- > Choose from our standard in-house colours or any RAL
- > Interior & exterior use, suitable for high saline environments



WHITE (RAL 9016)



BLACK (RAL 9005)



ANTIQUE BRONZE



SATIN ANTIQUE BRASS



SATIN BRASS



ANTHRACITE GREY (RAL 7016)



RAL COLOURS

## ACCESSORIES AND GLARE CONTROL OPTIONS

The LD1094 allows adjustments to be made to the direction of the optic and interchangeable accessories after installation through removal of the bezel. The HT1094 hand tool (see page 5) should be used when unscrewing the bezel and tilting the lens assembly to avoid scratching the fitting.



### /HL Honeycomb louvre

The honeycomb louvre can be added after installation and helps reduce glare from all angles



## ADJUSTABILITY

Featuring an innovative 360° rotating ball-joint, the lens assembly can be positioned in any direction and tilted up to 25° for ultimate flexibility when focusing on-site.

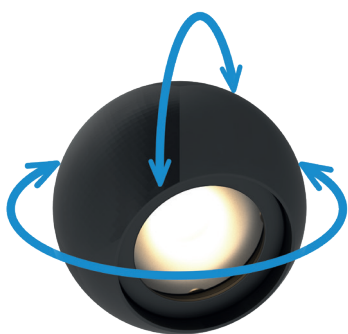

360° Rotation

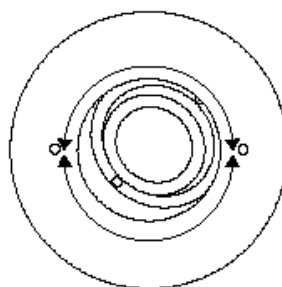

25° Tilt

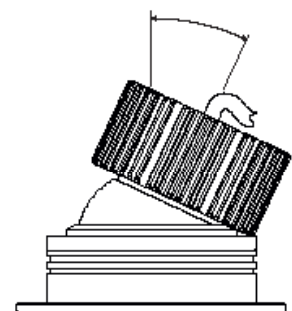

## HT1094 HAND TOOL

### /HT1094

The hand tool is required to unscrew the bezel and tilt the rotating ball-joint into the desired position for quick on-site focusing. The product can be tilted freehand, or with the supplied angle guide working in increments of 2.5° (from 0° up to 25°). The hand tool is completely plastic to prevent accidental scratches when opening and making adjustments. If commissioning a large group, then more than one tool may be required to allow multiple people to make adjustments at the same time. This tool is supplied separately and will be automatically quoted.



## HOW TO USE THE HAND TOOL

- 1 Fit the pins on the HT1094 into the corresponding holes on the front bezel of the fitting and begin to unscrew the bezel.

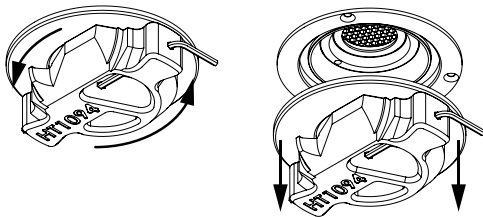

**NOTE: Keep bezel clean**

- 3 Always start in the level & upright position. Push towards the desired lit surface. If you overshoot, bring the LED back to the starting position before tilting again.

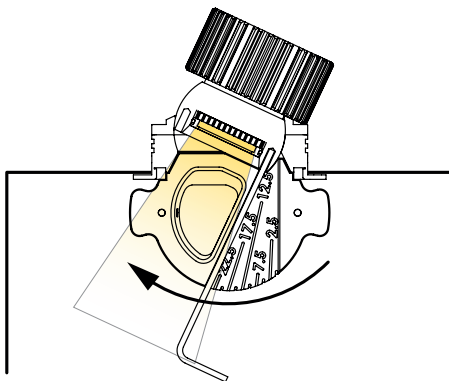

- 2 Place HT1094 into the LD1094 as shown. Using the provided Allen key or a 3mm screwdriver, push into module hole furthest away from the lit surface.

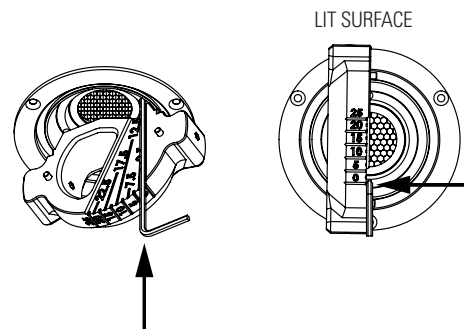

- 4 Make sure the inside of the bezel and glass is clean before refitting and replacing the bezel.

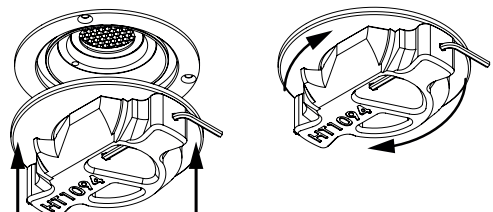



**FIXING OPTIONS**

**/SM Screw Mount**

Direct fitting to ceiling mounting method with the use of 3 hidden screws underneath the bezel, which is then screwed back on once fixing is complete. The fixing holes for the LD1094 are close to the cut-out diameter, so if the mounting surface isn't dense enough then there may be a risk of the fixing screws breaking out without the use of a ceiling ring (see CMR fixing on page 7).

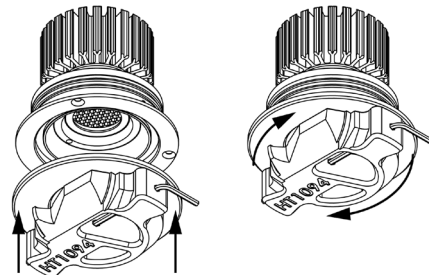
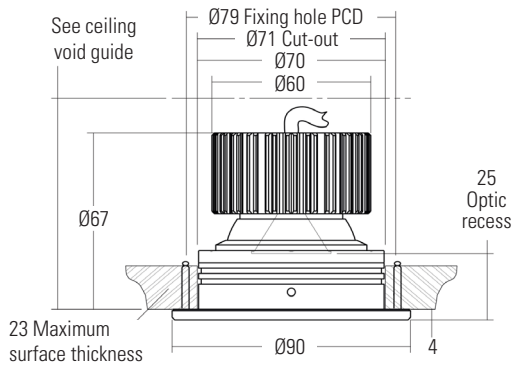
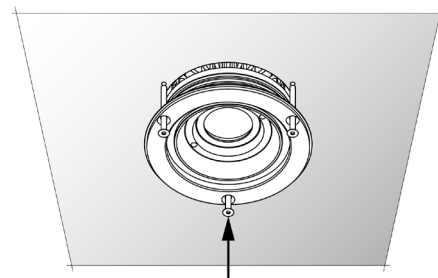
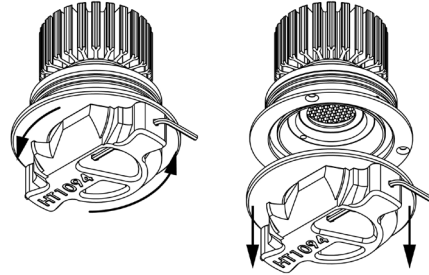

**/SC Spring Clips**

Suitable for use in surfaces with a thickness of 1mm – 23mm. Spring clips provide a simple, single fix mounting method.

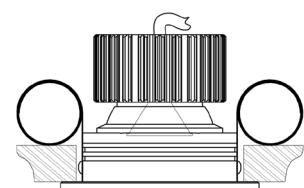
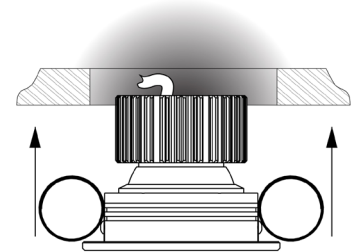
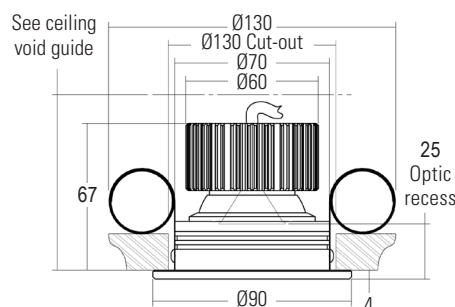
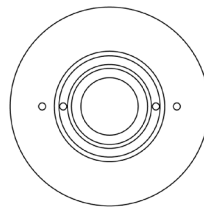

/CMR Ceiling Mount Ring

The ceiling mount ring is ideal for providing an extra secure fixing and is our recommended method. It can only be installed if there is access behind the mounting surface.

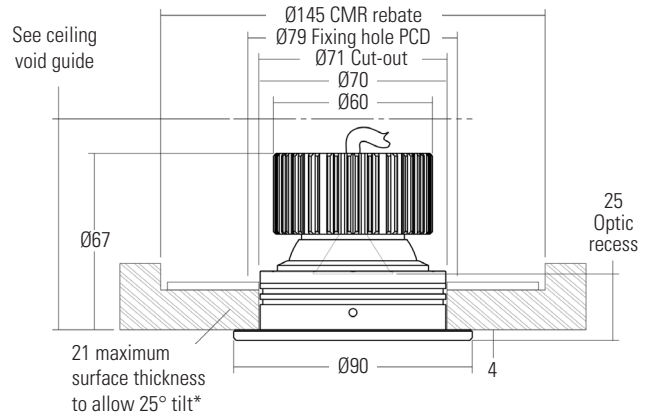

Why use the ceiling mount ring?

- > The fixing holes on the LD1094 bezel are close to the cut-out diameter, so if the mounting surface isn't rigid enough there may be a risk of the fixing screws breaking out without the use of a ceiling ring
- > The ceiling mount ring is manufactured from metal and has the threaded fixing holes pre-drilled
- > It provides a surface for the LD1094 to be fixed flush into the mounting surface

What is the thickness of the mounting surface?

The thickness of the mounting surface is important to how the ceiling ring is installed:

- > If this surface is 21mm in thickness then the ceiling ring can be fixed directly to the back of it
- > If the surface is thicker than 21mm then a rebate will need to be created to guarantee the bezel sits flush with the front surface

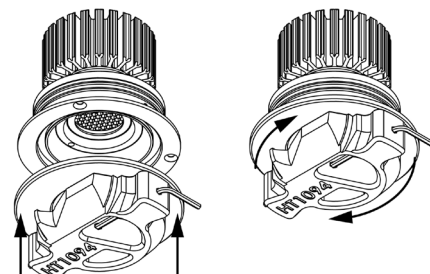
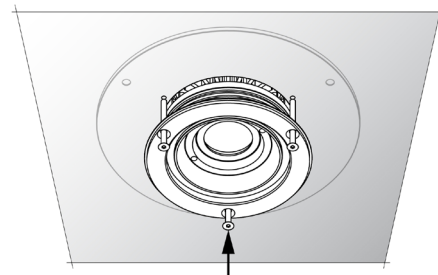
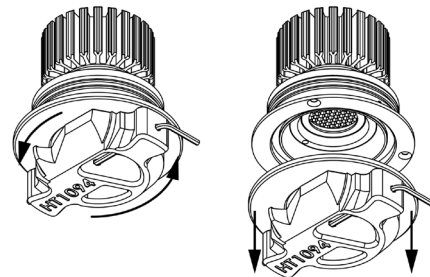

## CEILING VOID REQUIREMENTS

Installation requirements can vary but the minimum installation volume requirements must be adhered to. The volume of air within the void ensures that the thermal performance of the product is not compromised and that proper cooling of the LED can take place. The minimum void height is 80mm.

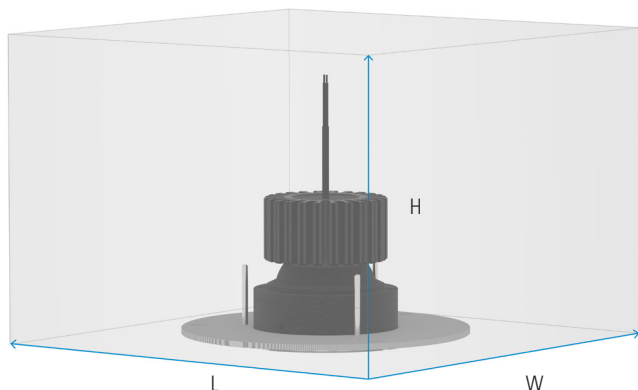

Output current	Minimum void dimension requirements (Lmm x Wmm x Hmm)	Minimum void volume	
		cm <sup>3</sup>	Litre(s)
350mA	150mm X 150mm X 80mm	1800cm <sup>3</sup>	1.8
500mA			
700mA	250mm x 250mm x 150mm	9375cm <sup>3</sup>	9.4

## CONE DIAGRAMS

Cone diagrams below are based on a 3000K N1 LED engine run at maximum output 700mA, 14W. Images below represent beam outputs when wall washing a 3m wall, spaced 125mm away from the lit surface. Photometric files (LDT) are included in the design pack which can be downloaded from the LD1094 product page on the website.

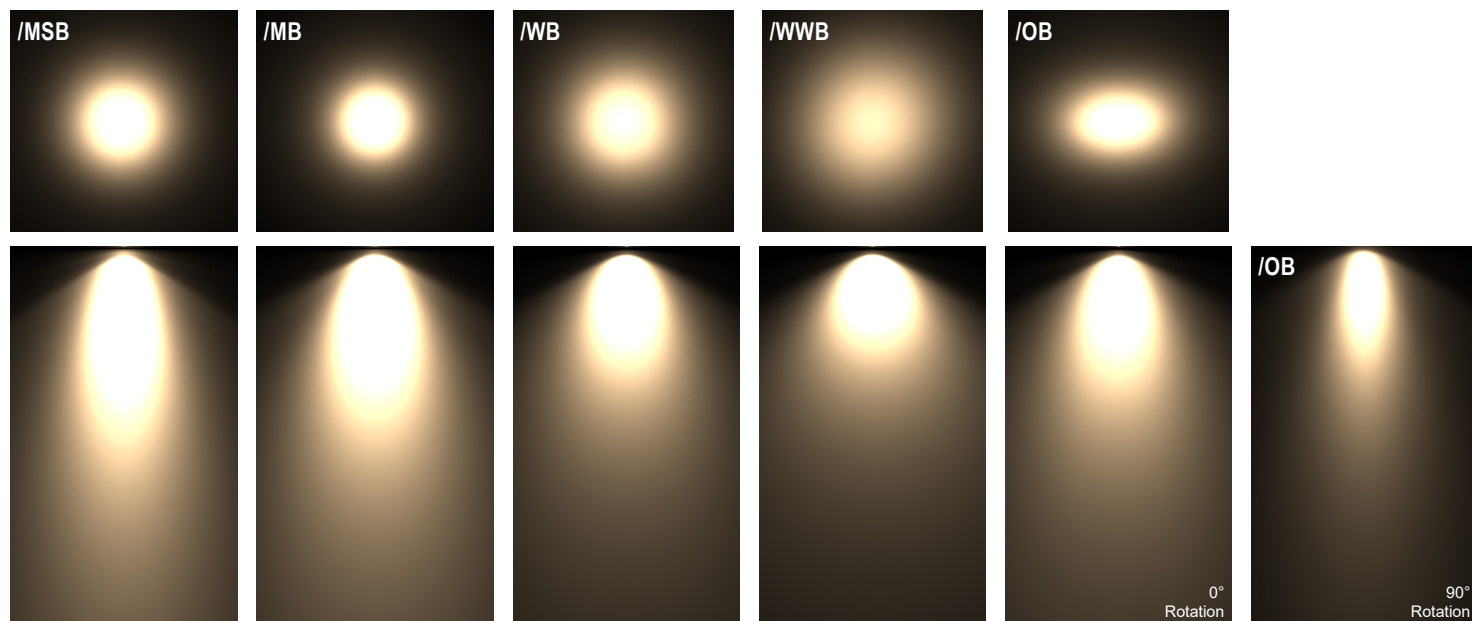

Medium Spot Beam  
700mA using a 28° optic

Distance (m)	Cone Width (m)	Luminance (lx)
3.0	0.23	921
2.5	0.47	1326
2.0	0.70	2071
1.5	0.94	3682
1.0	1.17	8285
0.5	1.41	33140

Cone Width (m)

Medium Beam  
700mA using a 35° optic

Distance (m)	Cone Width (m)	Luminance (lx)
3.0	0.30	364
2.5	0.60	524
2.0	0.91	819
1.5	1.21	1457
1.0	1.51	3277
0.5	1.81	13110

Cone Width (m)

Wide Beam  
700mA using a 46° optic

Distance (m)	Cone Width (m)	Luminance (lx)
3.0	0.40	147
2.5	0.81	211
2.0	1.21	330
1.5	1.62	587
1.0	2.02	1321
0.5	2.42	5283

Cone Width (m)

Extra Wide Beam  
700mA using a 65° optic

Distance (m)	Cone Width (m)	Luminance (lx)
3.0	0.61	64
2.5	1.22	92
2.0	1.82	144
1.5	2.43	256
1.0	3.04	575
0.5	3.65	2302

Cone Width (m)

Oval Beam  
700mA using a 22° X 43° optic

Distance (m)	Cone Width (m)	Luminance (lx)
3.0	0.39 / 0.22	237
2.5	0.78 / 0.43	342
2.0	1.16 / 0.65	534
1.5	1.55 / 0.86	949
1.0	1.94 / 1.08	2135
0.5	2.33 / 1.30	8540

Cone Width (m)



ORDER CODES & OPTIONS

EXAMPLE: LD1094-N1-700 / LW30 / NB / STAINLESS STEEL / HL / CMR

Light Engine & Drive Current	LED Colour	Beam Angle	Finish	Fixing & Accessories
LD1094 -				

 N1

7W LED at 350mA	LD1094-N1-350
10W LED at 500mA	LD1094-N1-500
14W LED at 700mA	LD1094-N1-700

Super Warm White (2200K)	/LW22
Extra Warm White (2700K)	/LW27
Warm White (3000K)	/LW30
White (4000K) - on request	/LW40
Cool White (5000K)	/LW50

28° Medium spot	/MSB
35° Medium	/MB
46° Wide	/WB
65° Extra wide	/WWB
22° x 43° Oval	/OB

	Polished & Passivated 316 Stainless Steel (for marine environments)
	316 Stainless Steel
	Paint Finish - White (RAL 9016)
	Paint Finish - Black (RAL 9005)
	Paint Finish - Antique Bronze
	Paint Finish - Satin Antique Brass
	Paint Finish - Satin Brass
	Paint Finish - Anthracite Grey (RAL 7016)
	Paint Finish - RAL

	/CMR
	/SC
	/SM
	/HL

**Drivers**  
Use with 350mA, 500mA & 700mA constant current LED drivers  
We have a range of dimmable LED drivers DMX and DALI compatible. Please see the downloads section on our website.