

LD51

MINIATURE SURFACE MOUNTED
ADJUSTABLE LED SPOTLIGHT



LD51 is a discreet, miniature surface mounted adjustable LED spotlight, with the versatility to meet a large range of applicational requirements. It has been specified on many of our most prestigious projects. The high-power LED is focused with a range of optics that offer excellent beam shape at various angles, thanks to a lockable tilt mechanism, that angles the fitting in the direction of the lit surface. It is manufactured from high quality machined components with glare control accessories and 5 fixing methods available, making it ideal for a variety of interior and exterior projects.

Design: Anchoe Iluminación | Project: Seasons Cantelejas, Madrid, Spain | Distributor: Distributionsa Product: LD51

Photography: Imagen Subliminal (Miguel de Guzman + Rocio Romero)

KEY FEATURES

- > High-power C1 light engine featuring NICHIA LED delivering upto 188lm and 90+ CRI
- > LED and high efficiency optic assembly recessed for reduced glare
- > Optional half or full cowl accessory to prevent glare from selected angles
- > 134° tilt mechanism on adjustable fixing methods
- > Machined from aluminium and available in the following paint finishes: White (RAL 9016), Black (RAL 9005), Silver, Antique Bronze, Satin Antique Brass, Satin Brass and Anthracite Grey (RAL 7016) or any RAL finish
- > 5 mounting methods including fixed and adjustable ground spikes
- >  Contains our integral moisture guard (anti-wicking barrier), stopping water ingress from going up the cable into the product from incorrect IP-rated connections
- > Switched, 0-10V, Casambi, DMX, DALI or Mains dimmable drivers available



DIMENSIONS

Dimensions in mm

For fixing dimensions please go to page 5.



WHITE LED ENGINE SPECIFICATION

Engine	 C1		
Beam angles	12°, 31°, 48°, 12° x 36°		
LED manufacturer	NICHIA		
Colour temperature	2200K / 2700K / 3000K / 4000K / 5000K		
Current [Rated Output]	350mA [1.2W]	500mA [1.7W]	700mA [2.4W]
Typical LED Circuit wattage	1.1W	1.6W	2.3W
Delivered lumens (L ₁₀₀)*	108	141	188
Delivered lm/Circuit W**	99	88	81
Typical LED Source wattage	1W	1.5W	2.1W
Source LED lm	133	187	206
Source lm/W	136	129	98
Forward voltage (V ₁₀₀)	2.8V	2.9V	3V
CRI	93		
Colour consistency	2 SCDM		
Peak intensity	1,145 cd		
LOR	0.91		
TM30	RF93 RG99		
UGR***	6.6	7.5	8.5
BUG rating ('downlight' mounted)	B0-U0-G0		
LED lifetime	L90B5 at 90,000hrs		
Applications			

This data is based on LD51-C1-700-LW30-NB

*Lumen output data applies to all colour temperatures

**LED wattage includes losses associated with using a 90% efficient driver

***UGR values based on room parameters of 4H 8H, C70 W50 F20

MECHANICAL

Ambient temperature	-20° to 50° (350mA-700mA)
Glass	3mm thick borosilicate
Materials	Anodised aluminium body with stainless steel fixing bracket.
Weight of product	0.012kg
IP rating	IP67
Wiring	In-series constant current wiring (pre-wired with 2 core cable at a length of 1000mm)

ENVIRONMENTAL

TM65	Available on request
TM66	2.8
Repair + Refurbish	 This product is included in our Repair and Refurbish scheme. This offers customers the ability to send back products to us for repair or refurbishment to extend their life without having to buy new fittings.
RLE (REPLACEABLE LIGHT ENGINE)	 Visit page 6 for replacement parts

AVAILABLE FINISHES

The LD51 body is machined from aluminium and painted in-house at LightGraphix. Paint finishes are suitable for interior and exterior use on surface mounted products. Our standard colours are below but we can accommodate any RAL request.



ALUMINIUM BLACK ANODISED
(STANDARD)

WET SPRAY



WHITE
(RAL 9016)



SATIN ANTIQUE BRASS



SATIN BRASS



SILVER ANODISED



ANTIQUÉ BRONZE



ANTHRACITE GREY
(RAL 7016)



RAL COLOURS

POWDER COAT



TEXTURED MARS BRONZE



TEXTURED FIR GREEN
(RAL 6009)

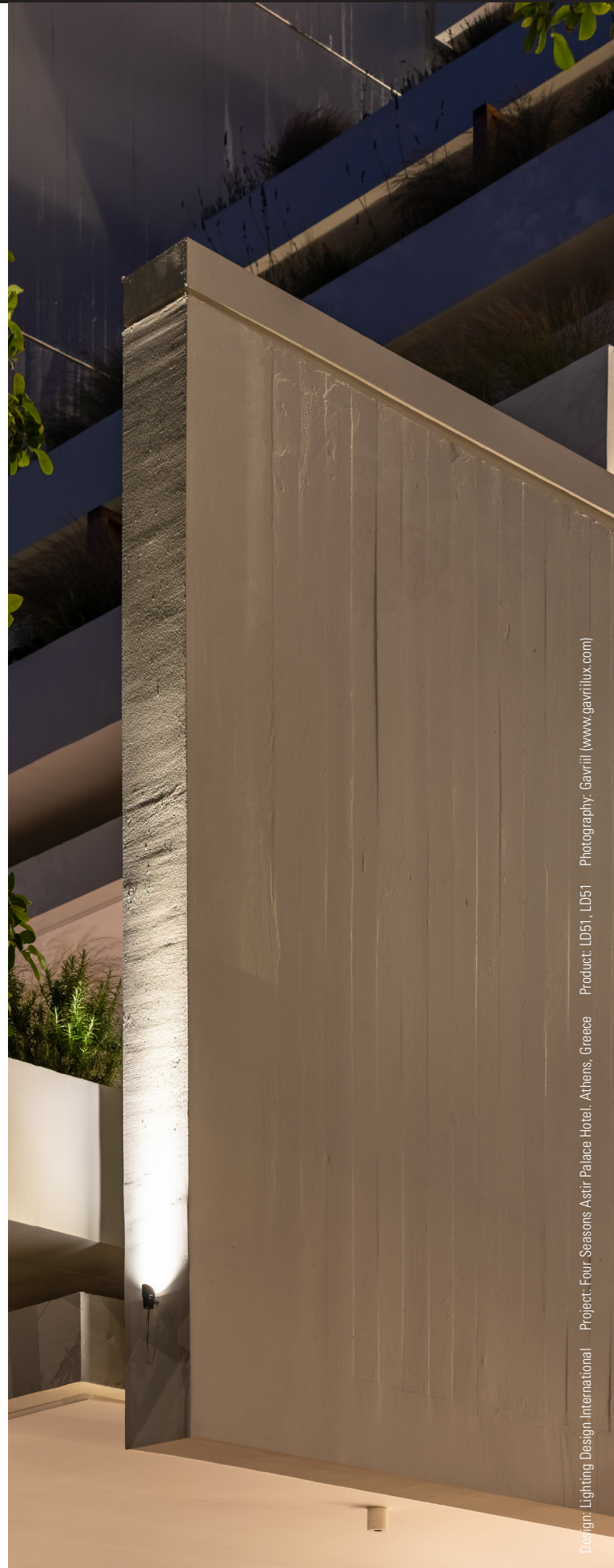

Design: Lighting Design International | Project: Four Seasons Astir Palace Hotel, Athens, Greece | Product: LD51, LD51 | Photography: Gavriil (www.gavriilux.com)

MOUNTING OPTIONS AND DIMENSIONS

Dimensions in mm

/SAM Surface adjustable mount

Supplied as standard with a Stainless Steel mounting bracket.

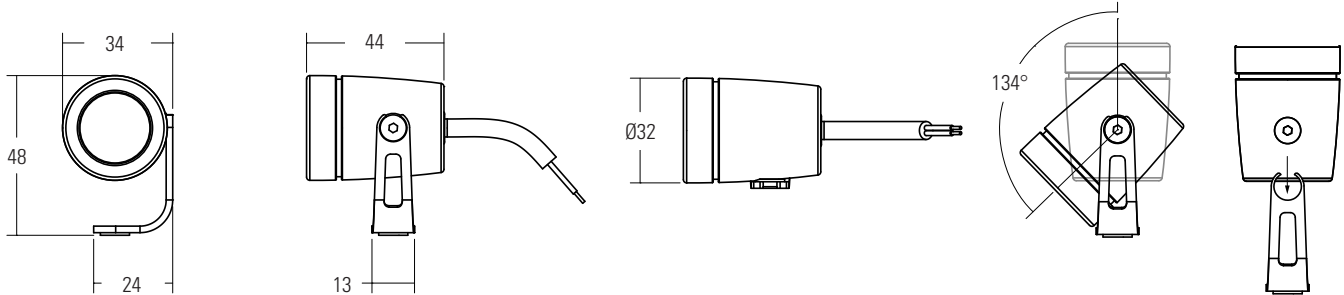

/GS Ground spike

The ground spike is manufactured out of stainless steel and painted to match the body. The standard length is 250mm.

/GSA Adjustable ground spike

The adjustable ground spike is manufactured out of stainless steel and painted to match the body. It is supplied with a 2m cable as standard.



/SMB Surface mount base

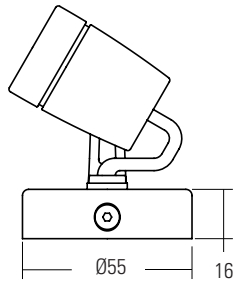

/TS Tree strap

The tree strap material grips and is tightened around the trunk. A tilt adjustment of 10° can be achieved towards the tree to provide a vertical beam.

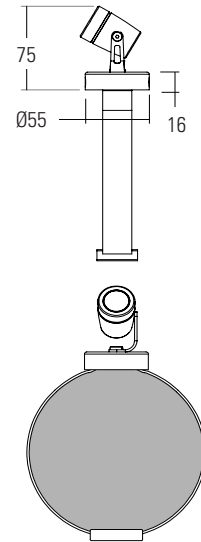

Trunk measurements:
1400mm circumference
Ø450 maximum diameter

GLARE CONTROL OPTIONS

/HC51 Anti-glare half cowl

With the aid of an O-ring the aluminium cowl is securely fitted to the LD51. This allows it to be rotated in any direction to reduce glare.

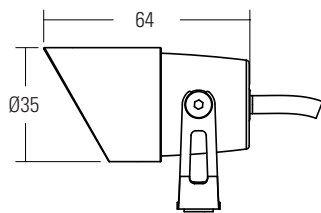

/FC51 Anti-glare full cowl

With the aid of an O-ring the aluminium cowl is securely fitted to the LD51. The full cowl reduces glare from all angles.

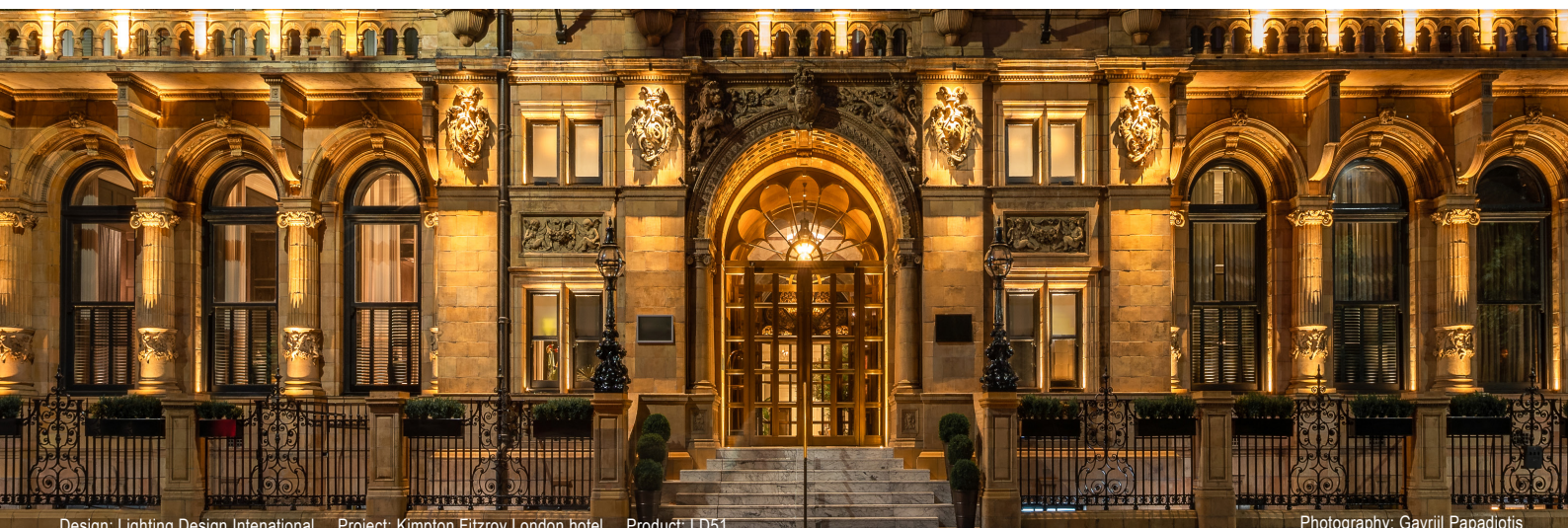
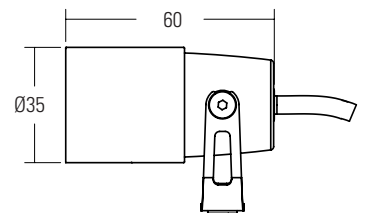

Design: Lighting Design International Project: Kimpton Fitzroy London hotel Product: LD51

Photography: Gavriil Papadiotis

RLE - REPLACEABLE LIGHT ENGINES



What is RLE

On the surface, RLE is LightGraphix's answer to the Circular economy question that is facing many industries at the moment. However for us, RLE is an ethos; a commitment that LightGraphix will factor in the principles of good circular design into all of its future product design. It allows us to offer luminaires that contain replaceable, energy-efficient light engines. This gives customers the ability to refurbish existing lighting installations rather than having to replace the entire luminaire. This will fall into two types of refurbishments: replaceable, and repairable.

RLE Engines

Repairs can be conducted on any site worldwide, or in our factory, with a small tool. Simply swap out the singular modular LED insert, and replace it with another, along with a new optic, which are both supplied by us. The warranty provided with the product varies based on who is performing RLE repairs. There are three types of RLE engine, categorised based on the size of the product. RLE1 is the smallest, with RLE3 being the largest.



Used in the following products:
LD41, LD43DR, LD43DRG, LD44,
LD44G, LD47, LD51, LD56, LD56T,
LD57SQ, LD60, LD61, LD62,
LD64 & LD65

LD51 RLE REPLACEMENT PARTS

Please use the configurator below to specify your replacement engine and optic. If you are unsure of your original specifications, please check the label on your LightGraphix fitting, or get in touch with our sales team. Installation sheets will be supplied with the new components.

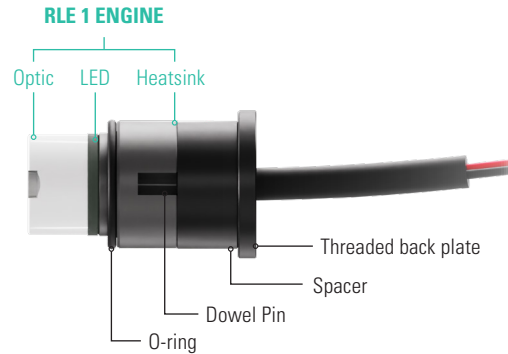

RLE Engine		LED Colour		Beam Angle		Accessories	
RLE1/							
RLE 1 ENGINE	RLE1/	Super Warm White (2200K)	/LW22	Narrow beam 16mm optic	RLE/OP-16/NB	Dowel pin for Oval beam orientation	RLE1/OP-16/DP
		Extra Warm White (2700K)	/LW27	Medium beam 16mm optic	RLE/OP-16/MB	O-ring	RLE/OR
		Warm White (3000K)	/LW30	Wide beam 16mm optic	RLE/OP-16/WB	Threaded back plate	RLE/TBP
		White (4000K) - on request	/LW40	Oval beam 16mm optic	RLE/OP-16/OB	Spacer for LD51	RLE/SP1
		Cool White (5000K)	/LW50				

ORDER CODES & OPTIONS

Example: LD51-C1-700 / LW30 / MB / Black / CO / GS

Light Engine & Drive Current

LED Colour

Beam Angle

Finish

Fixing & Accessories

LD51 - / / / /

WHITE LED ENGINES







C1

1.2W LED at 350mA	LD51-C1-350
1.7W LED at 500mA	LD51-C1-500
2.4W LED at 700mA	LD51-C1-700

Super Warm White (2200K)	/LW22
Extra Warm White (2700K)	/LW27
Warm White (3000K)	/LW30
White (4000K) - on request	/LW40
Cool White (5000K)	/LW50
Red	/LR
Green	/LG
Blue	/LB
Amber	/LA

12° Narrow spot	/NB
31° Medium	/MB
48° Wide	/WB
12 x 36° Oval	/OB

	Aluminium black anodised (standard)
	WET SPRAY White (RAL 9016)
	WET SPRAY Silver anodised
	WET SPRAY Antique Bronze
	WET SPRAY Satin Antique Brass
	WET SPRAY Satin Brass
	WET SPRAY Anthracite Grey (RAL 7016)
	WET SPRAY RAL Colours
	POWDER COAT Textured Mars Bronze
	POWDER COAT Textured Fir Green (RAL 6009)

	/SAM
	/GS
	/GSA
	/SMB
	/TS
	/HC51
	/FC51

Drivers
Use with 350mA, 500mA & 700mA constant current LED drivers
We have a range of dimmable LED drivers including DMX and DALI compatible.
Please see the downloads section on our website.